

[Priskuranter] - 13

Aktiebolaget Bofors-Gullspång

Vardagstryck Affärstryck
1800-tal 8:o



National Library
of Sweden

**THE BOFORS-
GULLSPÅNG Co.,
LIMITED,
BOFORS, SWEDEN**

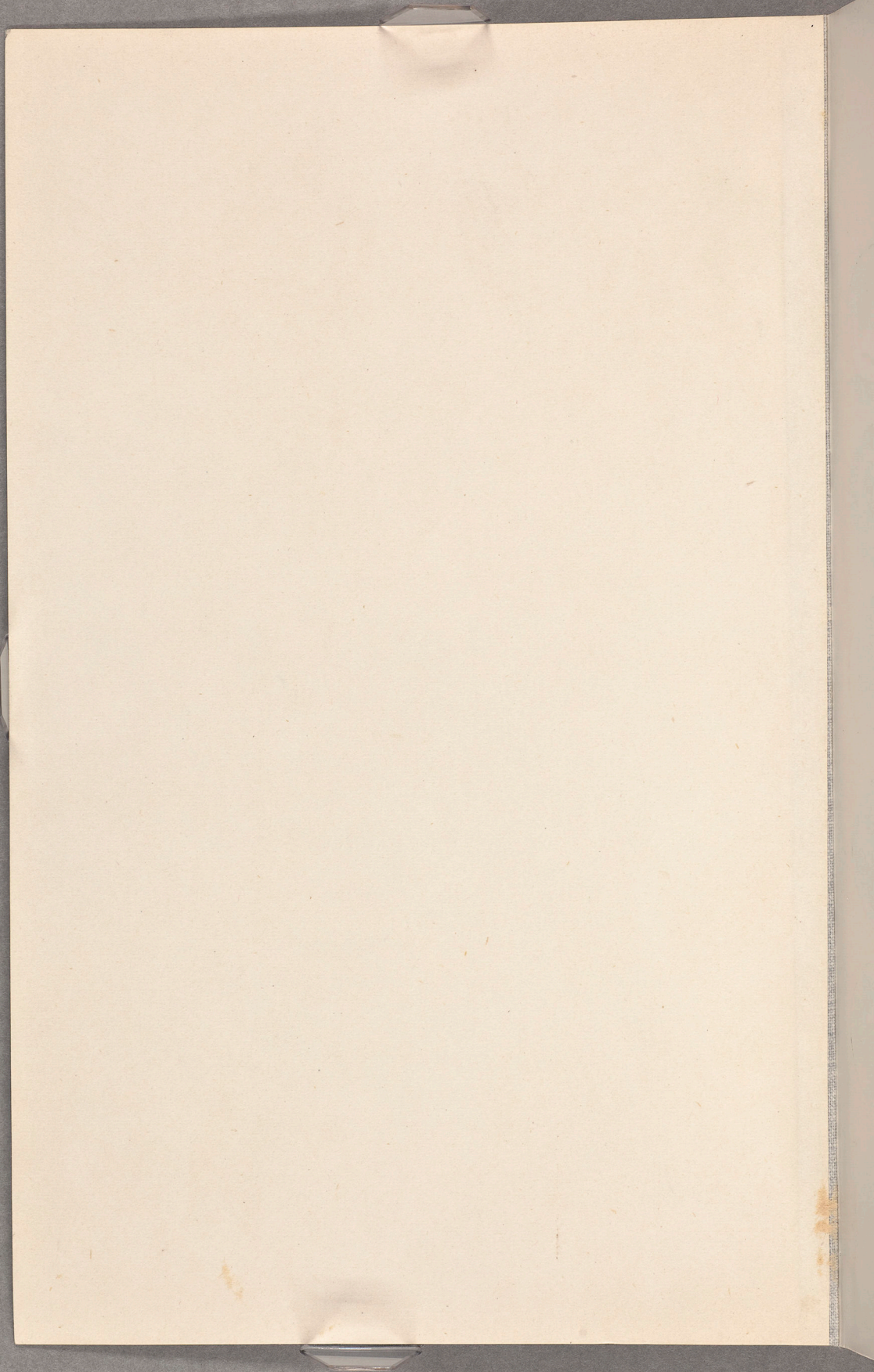

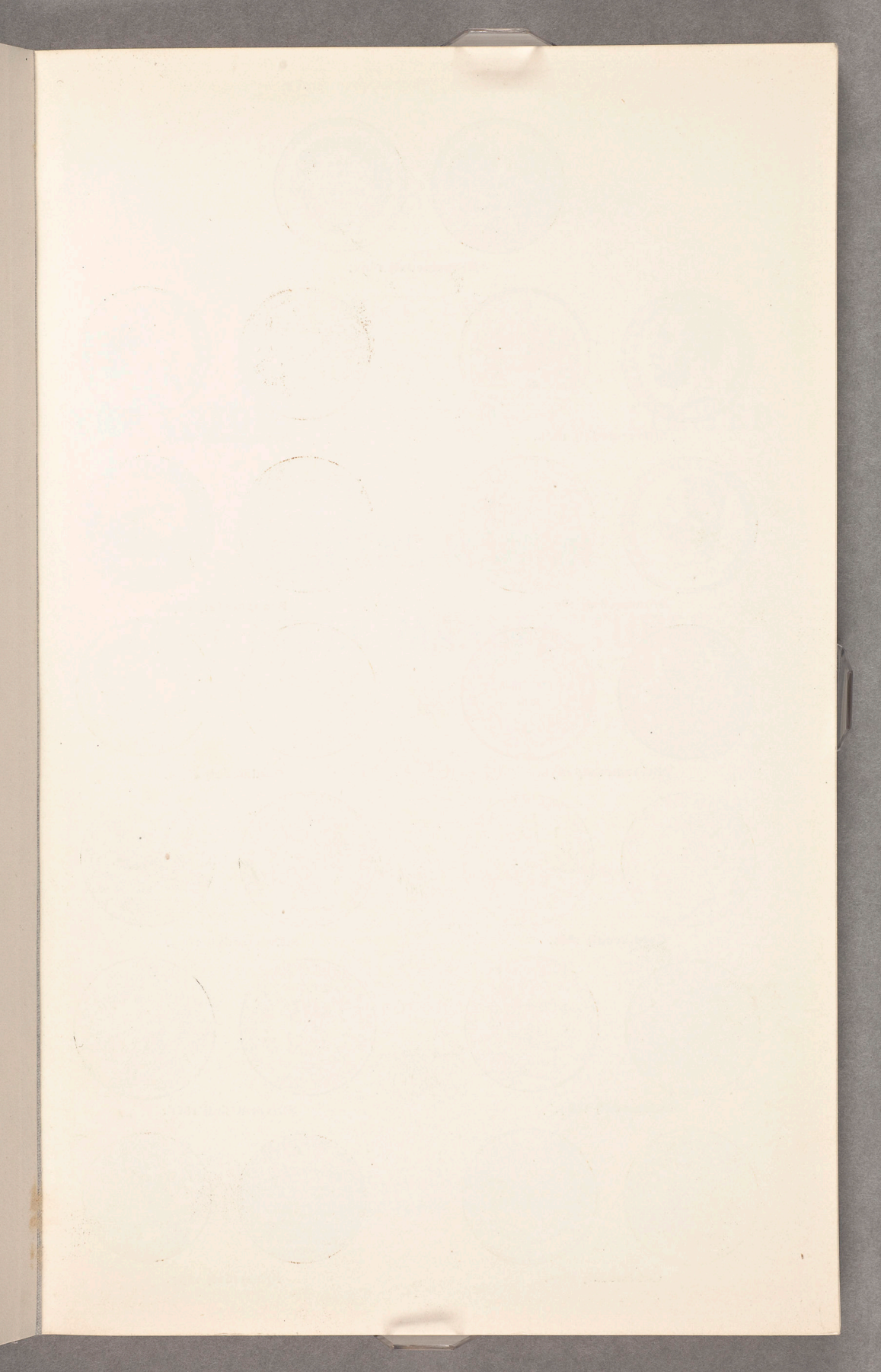



Bronzemedalj 1862.

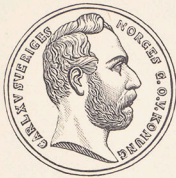

Silfvermedalj 1866.

Bronzemedalj 1867.



Bronzemedalj 1873.

Bronzemedalj 1876.



Silfvermedalj 1878.

Guldmedalj 1878.

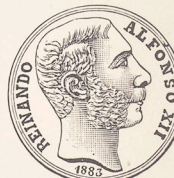
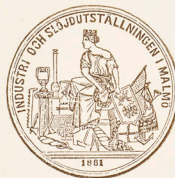

Guldmedalj 1881.

Silfvermedalj 1883.

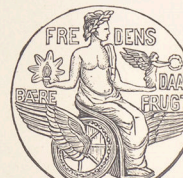

Guldmedalj 1884.

Silfvermedalj 1888.



Guldmedalj 1891.

Prismedalj 1893.

ILLUSTRATED CATALOGUE

AND

PRICE LIST

THE BOFORS-GULLSPÅNG Co., LIMITED

**SIEMENS-MARTIN
CAST STEEL MANUFACTURES**

AT

BOFORS

POSTAL AND TELEGRAPHIC ADDRESS: BOFORS

THE PRICES ARE CALCULATED FREE ON TRUCK

AT THE BOFORS STATION

STOCKHOLM 1897

PRINTED BY HASSE W. TULLBERG

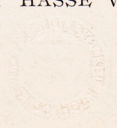

THE BOARD OF DIRECTORS

CAST STEEL MANUFACTURING



Steel Castings made by the Siemens-Martin Process of all kinds and any temper up to a weight of 20 Tons, and to any patterns or drawings.



If the Castings are to be made to patterns the latter should be 1.8 % larger than the castings required.



Patterns are charged extra.



On demand the Castings will be tested by Lloyd's or Veritas' Swedish Surveyors.



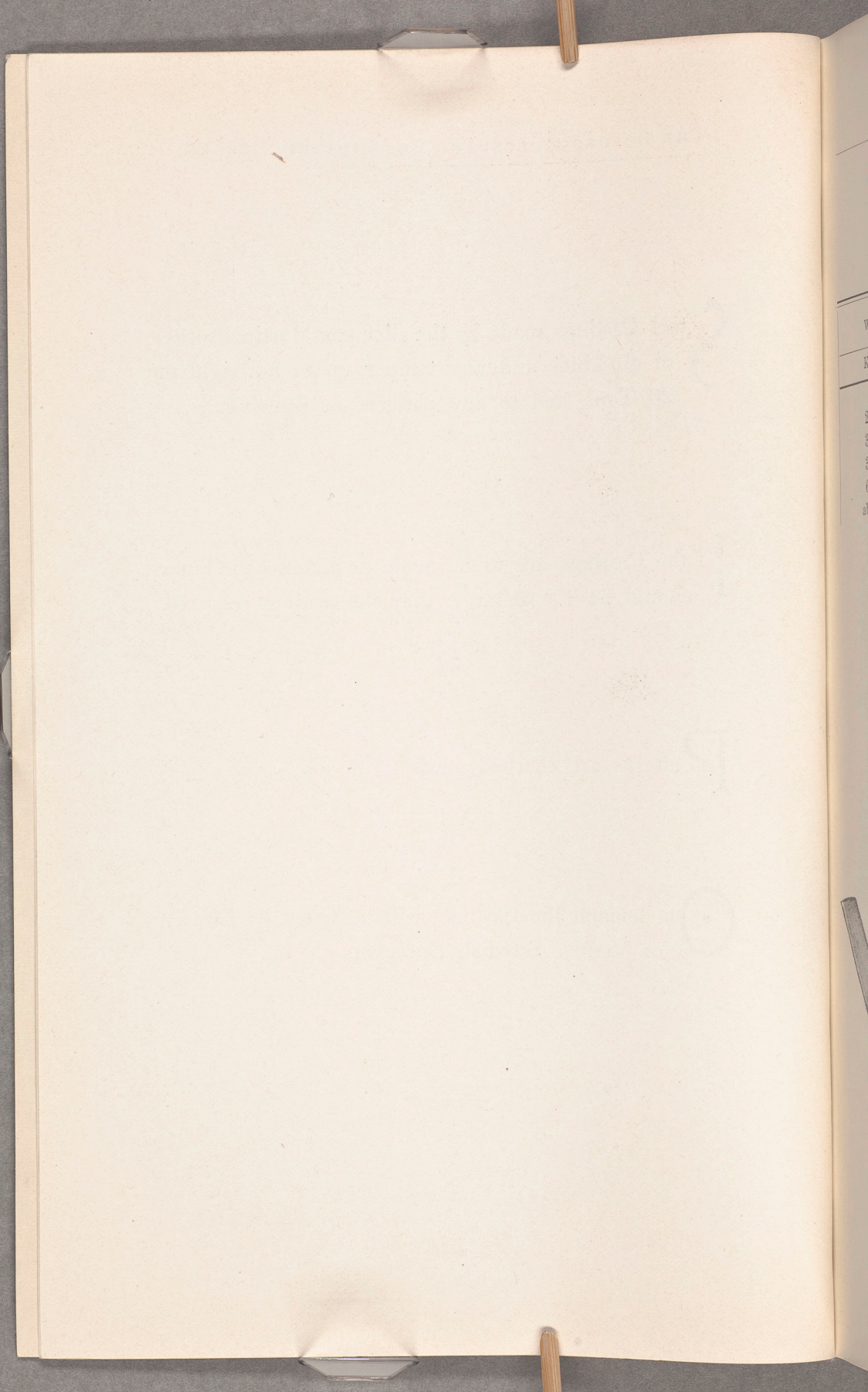

Stem.

WEIGHT	PRICE PR 100 KG.
Kilogram	
250—300	
300—350	
350—600	
600—800	
above 800	

Weight

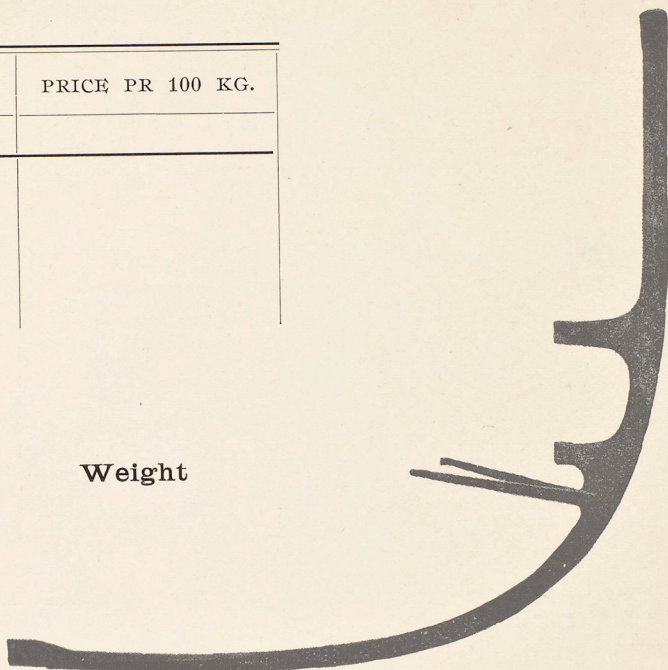

Weight

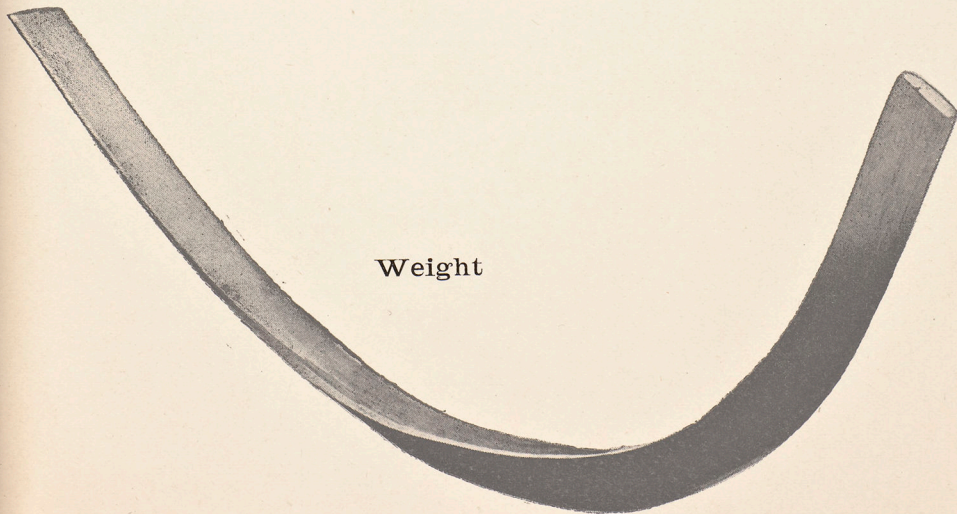

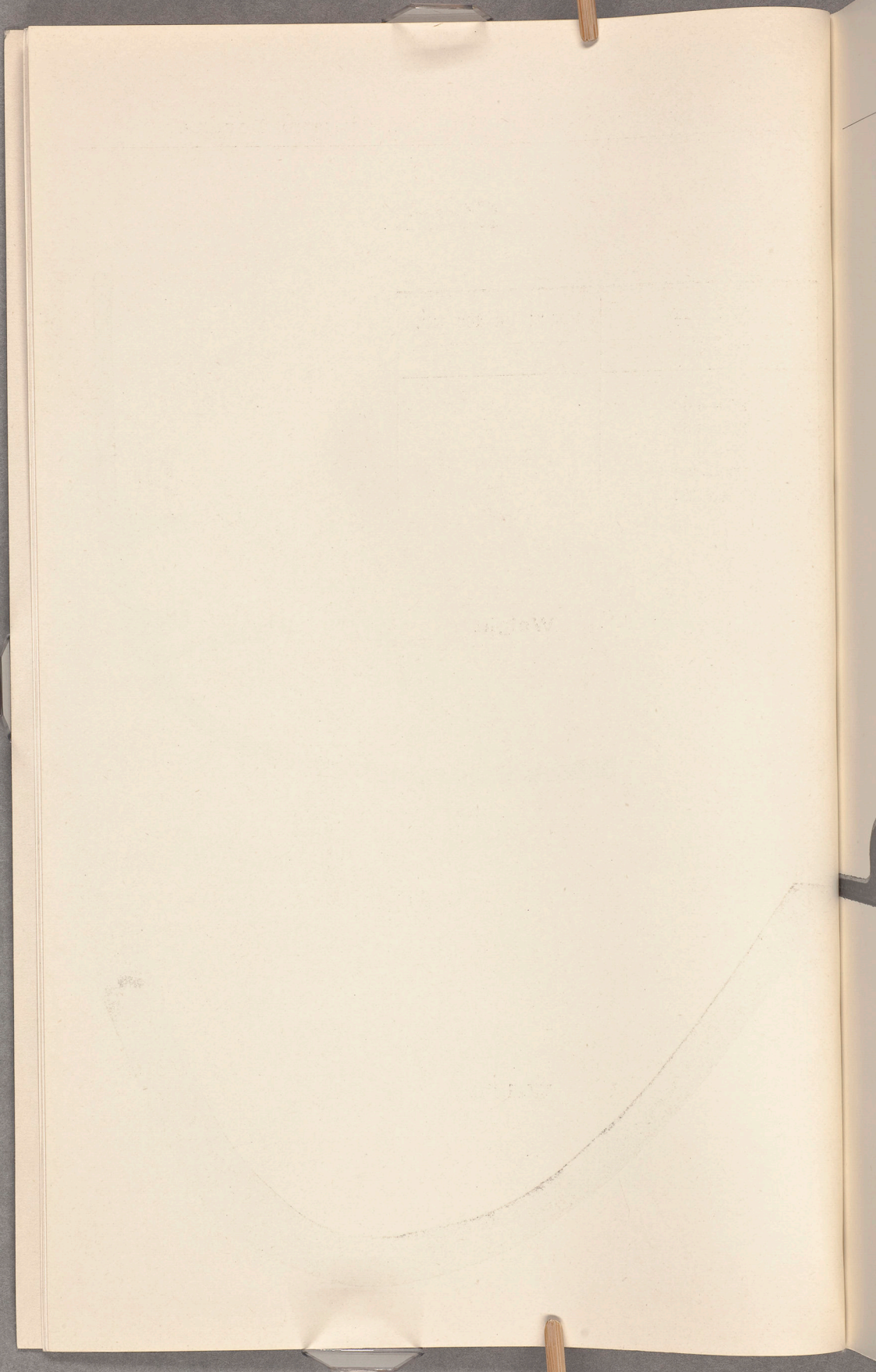

Stern Frame.

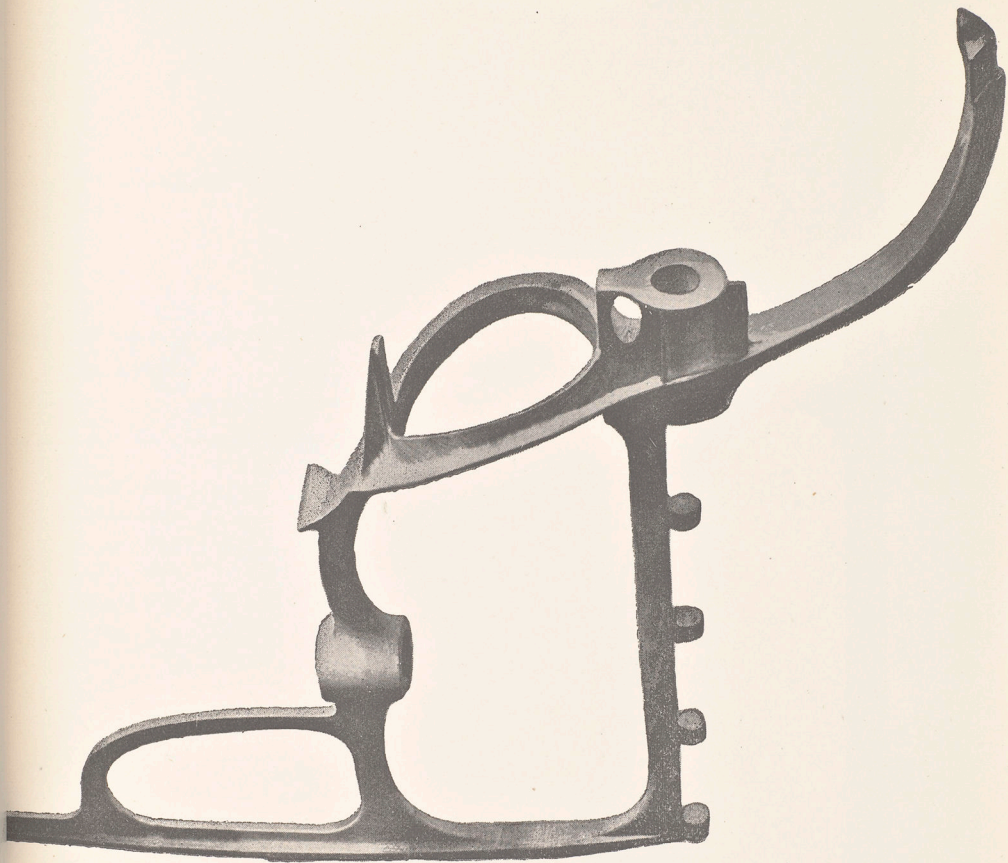

Weight

WEIGHT	PRICE PR 100 KG.
Kilogram	
250—300	
300—350	
350—600	
600—800	
above 800	

Stern Frame.

Weight

WEIGHT	PRICE PR 100 KG.
Kilogram	
250—300	
300—350	
350—600	
600—800	
above 800	

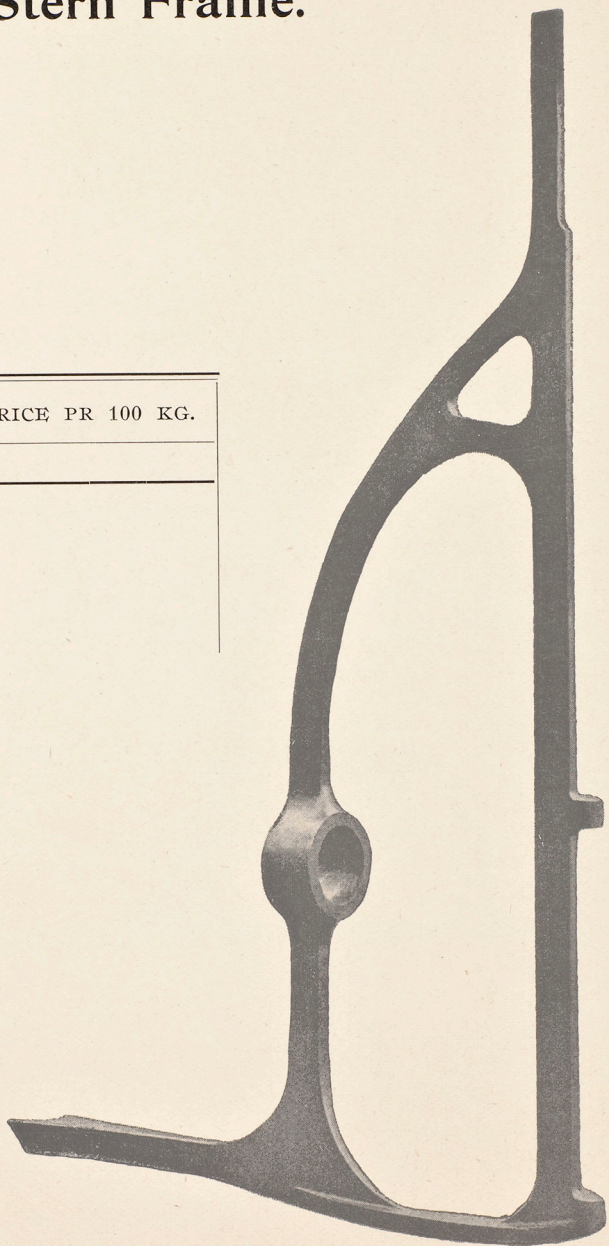

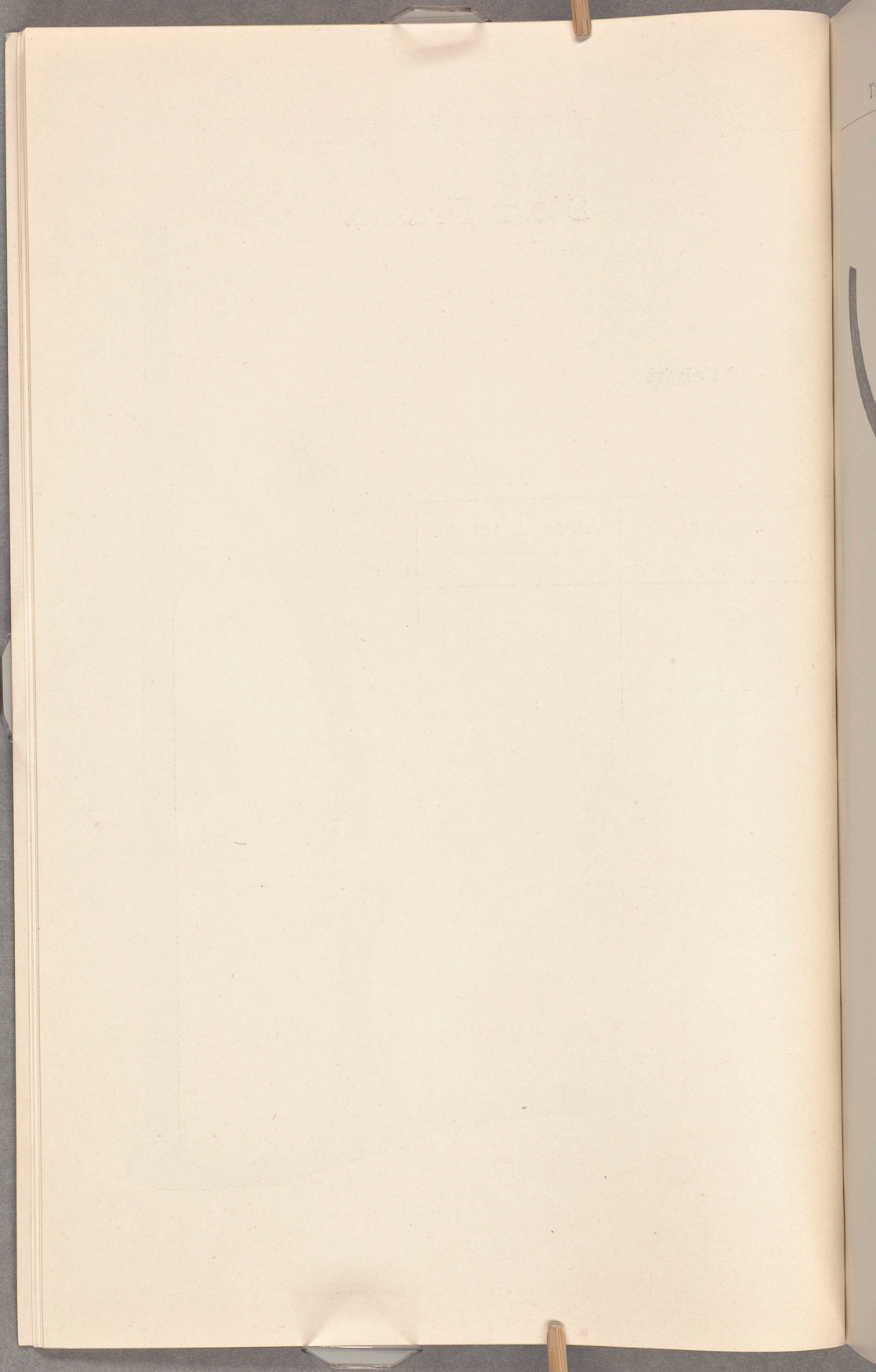

Stern Frame.

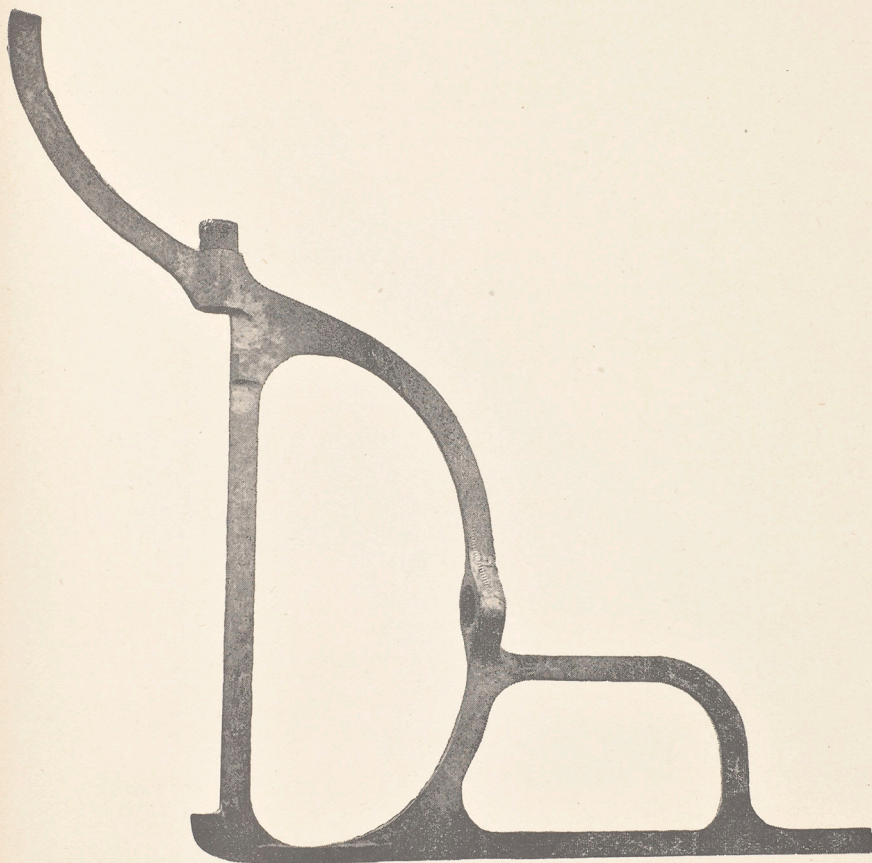

Weight

WEIGHT	PRICE PR 100 KG.
Kilogram	
250—300	
300—350	
350—600	
600—800	
above 800	

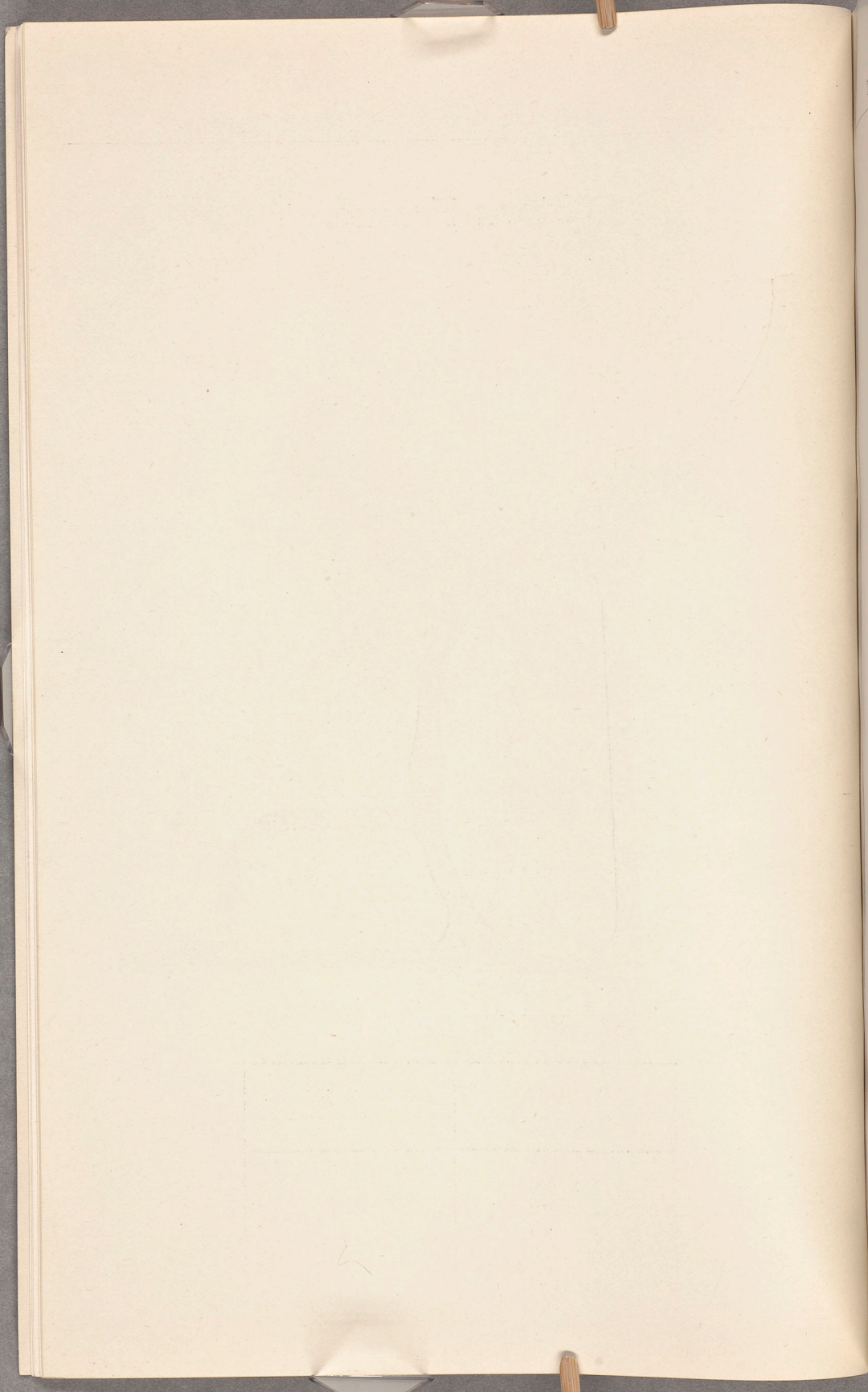

The Robot

R

100 kg.

Ram for Ironclads.

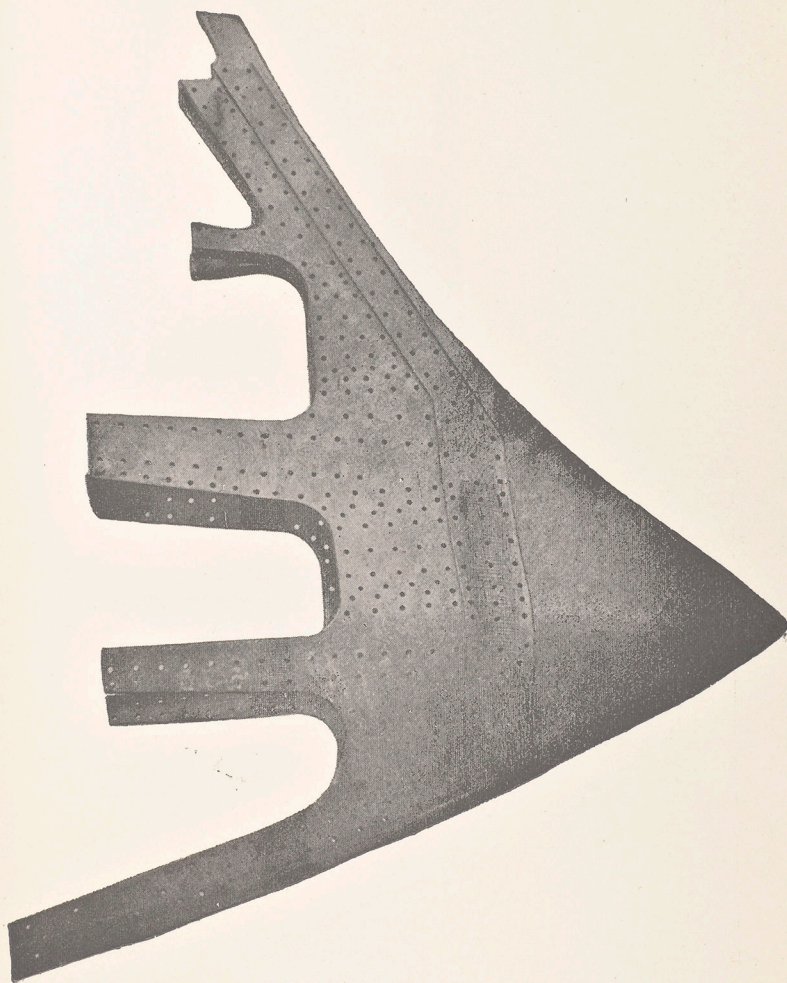

Weight

Price pr 100 kg.

THE UNIVERSITY OF CHICAGO

Department of Chemistry



CHICAGO, ILL.

THE BOFORS-GULLSPÅNG CO., LIMITED, BOFORS.

Ram for Ironclads.

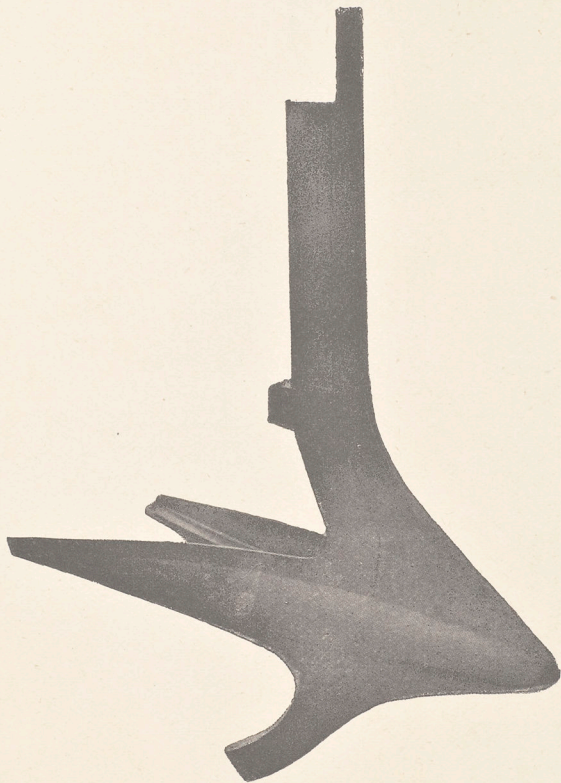

Weight

Price pr 100 kg.

1880

1880

Propeller Shaft Stays.

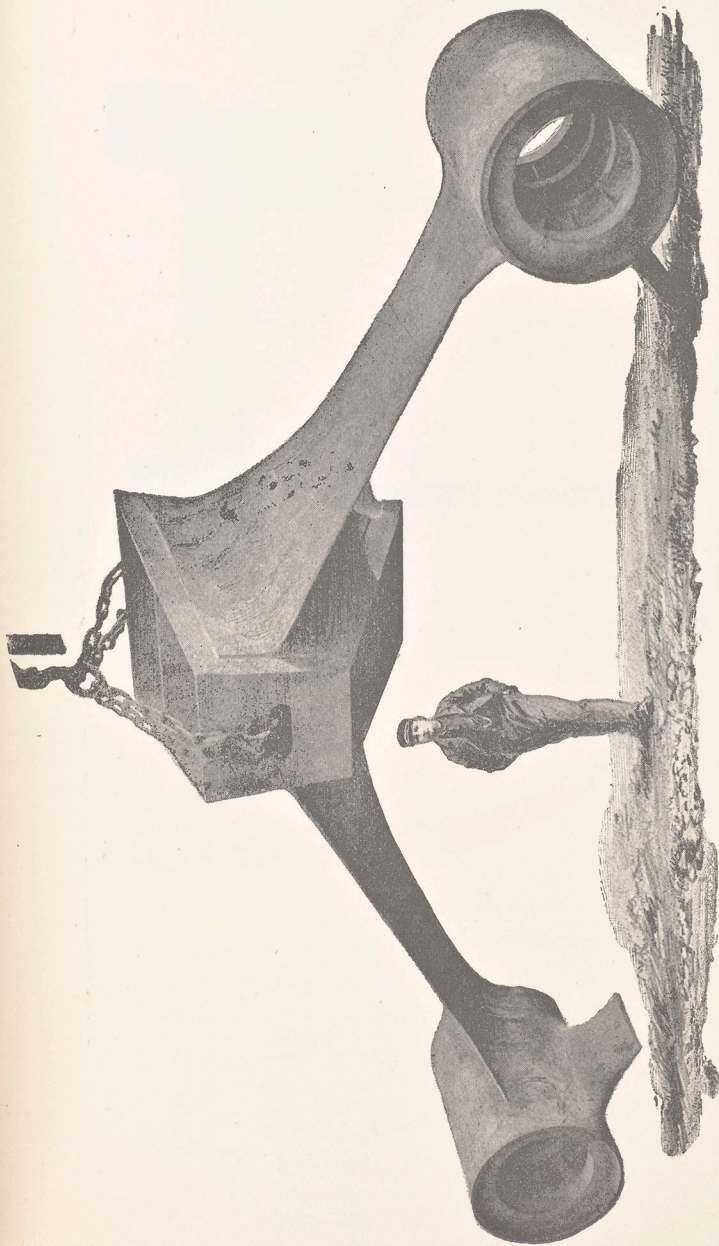

Cast in one piece.

Weight

Price pr 100 kg. -----



Rudder Frame.

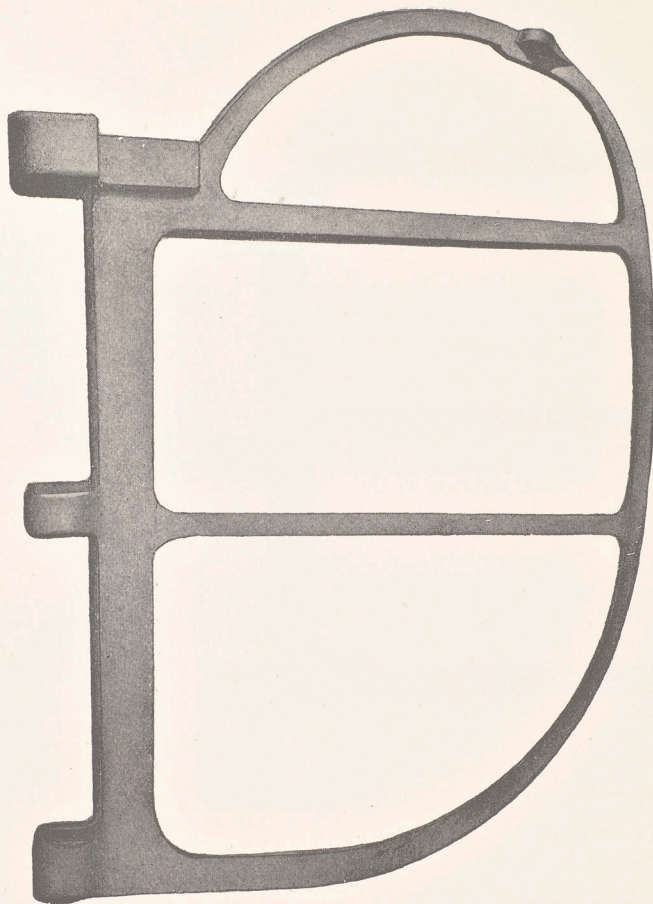

Weight

WEIGHT	PRICE PR 100 KG.
Kilogram	
Below 250	
250—300	
300—350	
350—600	
600—800	
above 800	

The Bo
Rudder



Rudder.

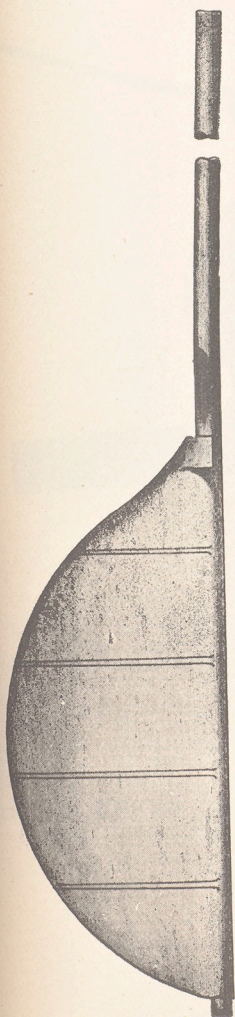

Rudder Frame.

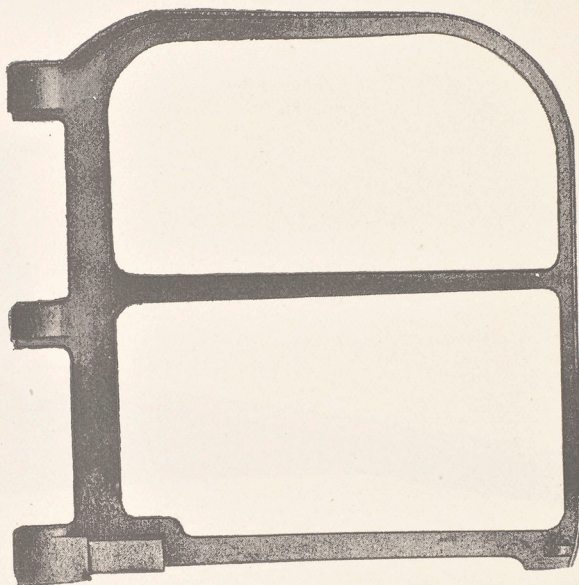

WEIGHT	PRICE PR 100 KG.
Kilogram	
Below 250	
250—300	
300—350	
350—600	
600—800	
above 800	

The Bofors

Boss &

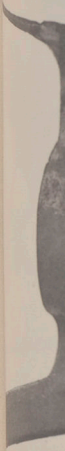

10 kg

THE BOFORS-GULLSPÅNG CO., LIMITED, BOFORS.

Boss and Propeller Frame.

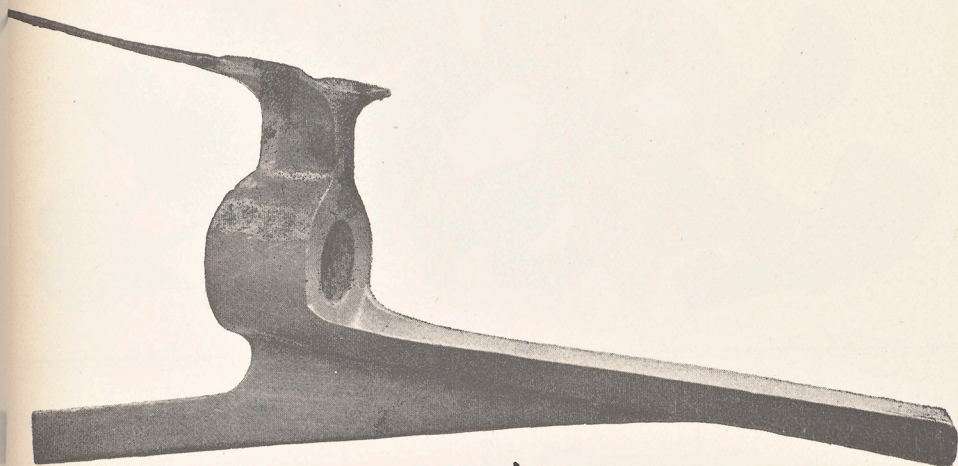

Weight

Price pr 100 kg.

Cast S



	EXTRA
	PER PIECE

the diameter
will be char
takes all sizes
Dress-weight 3
> 6
> 12
> 40
rollers and 1
for fixing

Cast Steel Propellers.

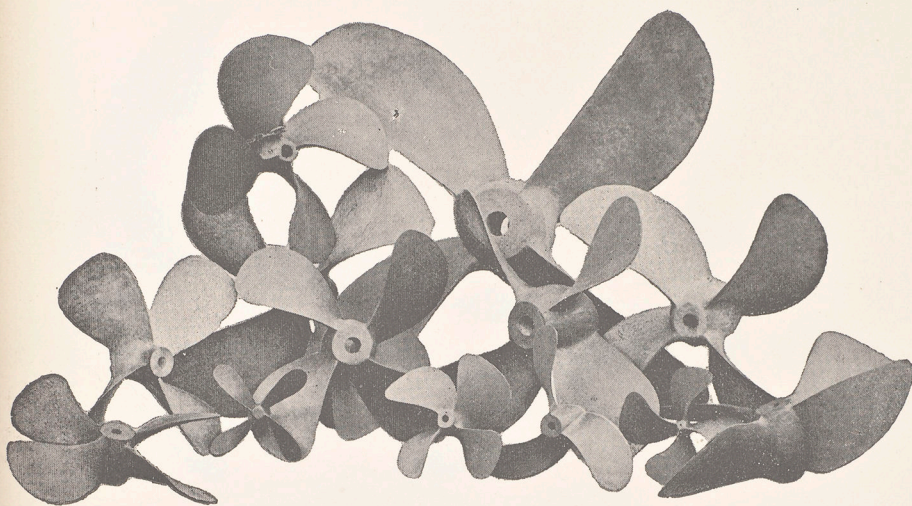

DIAMETER	EXTRA PR PIECE	PRICE PR 100 KG.	DIAMETER	EXTRA PR PIECE	PRICE PR 100 KG.
3 Feet and less.....			11 Feet.....		
4 »			12 »		
5 »			13 »		
6 »			14 »		
7 »			15 »		
8 »			16 »		
9 »			16 ¹ / ₂ »		
10 »			17 »		

If the diameter exceeds any of the above dimensions the propeller will be charged for at the next higher size.

Propeller Blades all sizes. (Pattern extra)

Propeller Bosses-weight 30—60 kg.

» » 60—150 »

» » 150—400 »

» » 400 kg. and above

Propellers and Propeller Blades will be delivered — if desired — complete ready for fixing.

Stream Anchor.

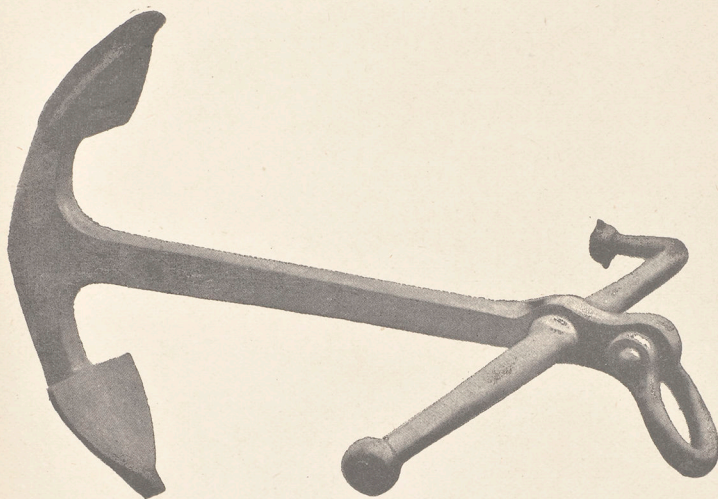

Weight

Price pr 100 kg. -----

Kedge.

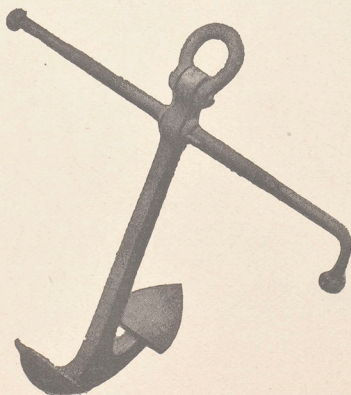

Weight

Price pr 100 kg. -----



kg

last Ho

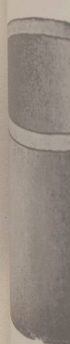

kg

Mushroom Anchor.

(Mud Anchor).

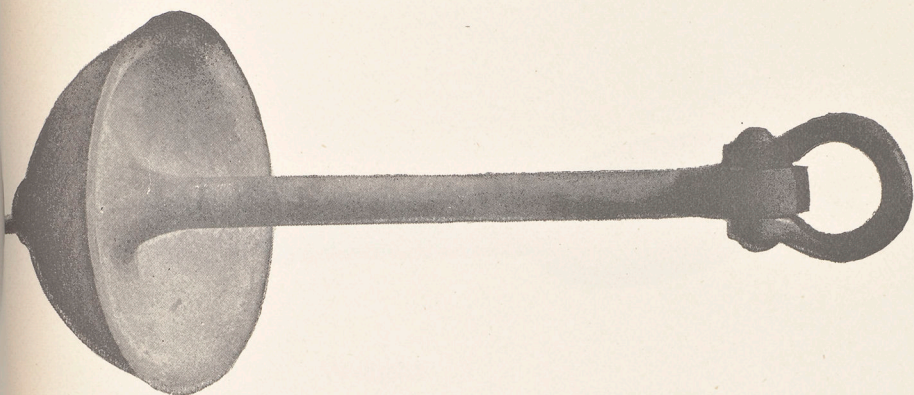

Weight

Price pr 100 kg.

Mast Hoop.

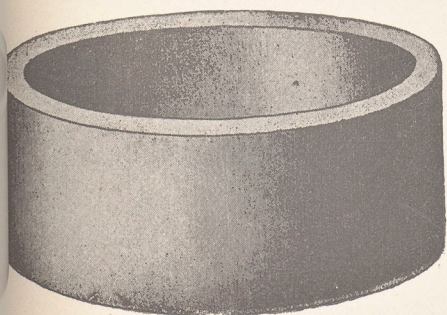

Bits.

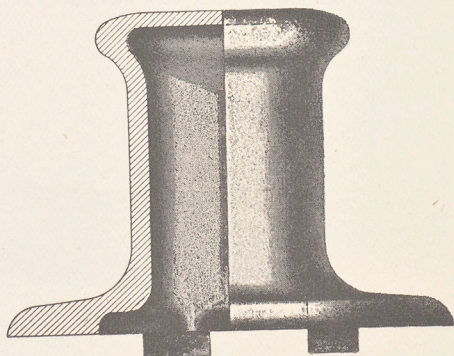

Price pr 100 kg.

100 kg

10 kg

Hawse Pipes.

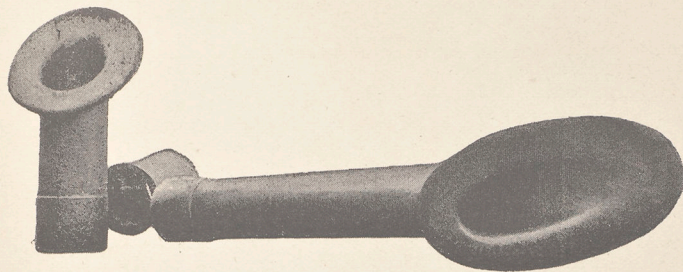

Weight

Price pr 100 kg.

Hawse Pipes.

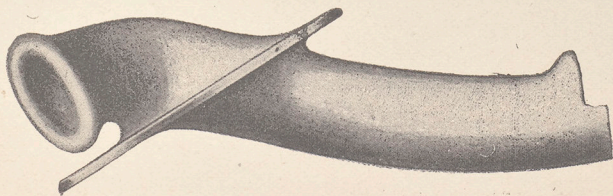

Weight

Price pr 100 kg.



Davit Sockets.

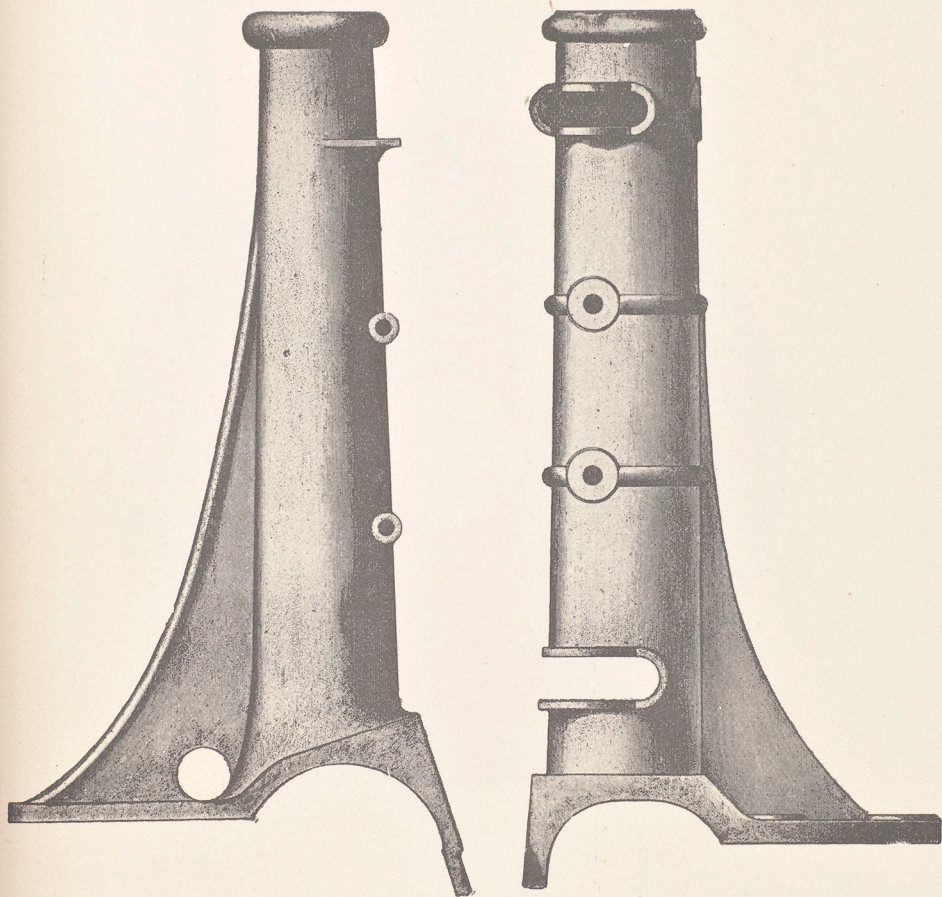

Price pr 100 kg. -----



THE BOFORS-GULLSPÅNG CO., LIMITED, BOFORS.

Paddle Wheel Boss.

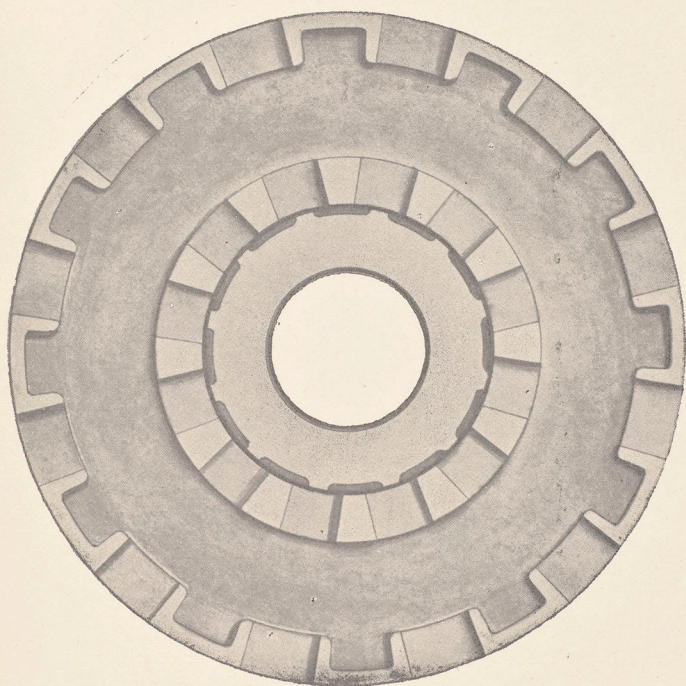

Price pr 100 kg.

POPS-GULLS

ing Rod.

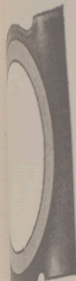

Connecting Rod.

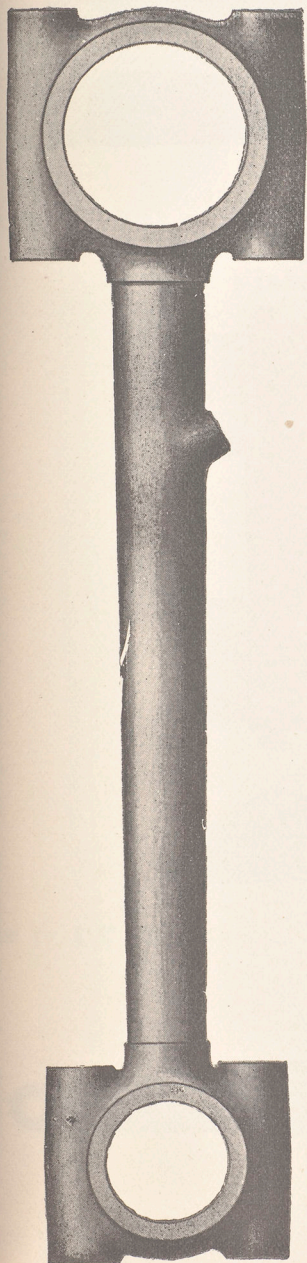

Double Crank.

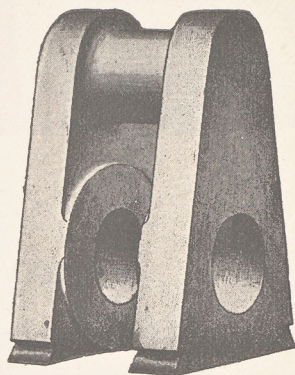

Crank Dish.

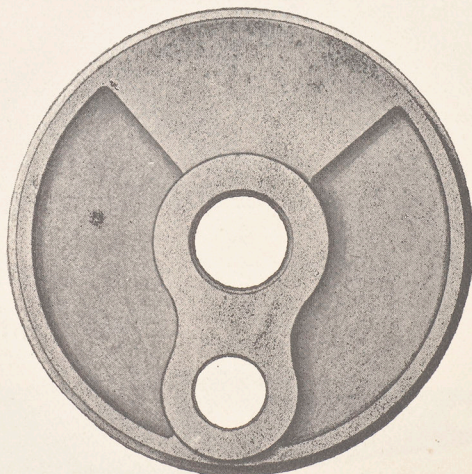

Price pr 100 kg.

kg

Pis

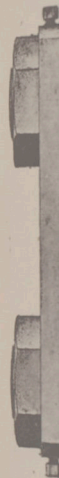

kg

kg

Piston.

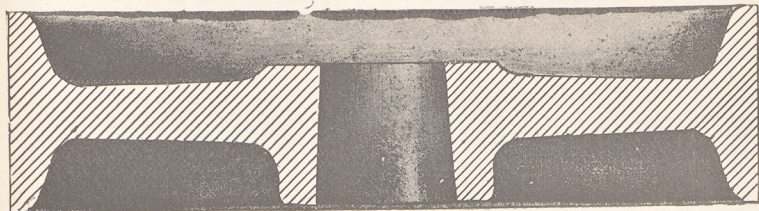

Price pr 100 kg. -----

Piston Rod Crosshead.

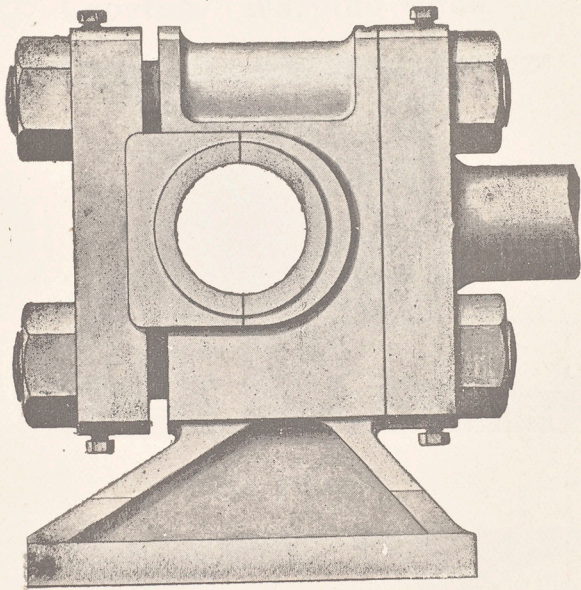

Price pr 100 kg. -----

Pump Lever.

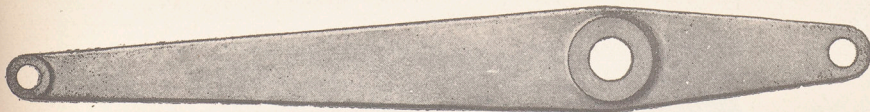

Price pr 100 kg. -----

Caps



Caps



C



Capstan with parts.

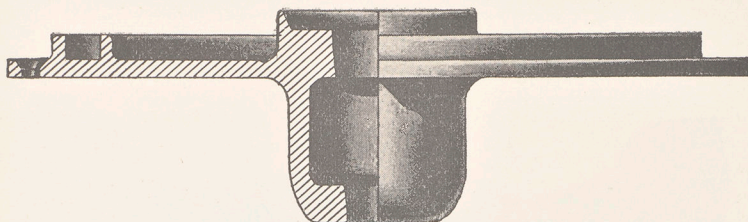

Capstan. Warping Ends.

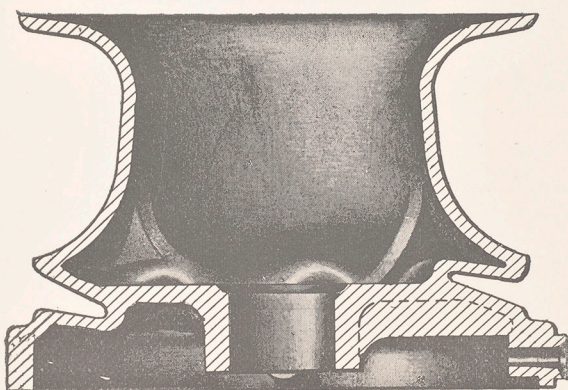

Fair leader.

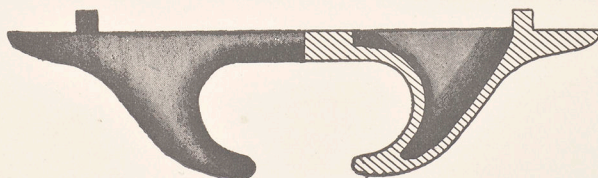

Capstan Drumhead.

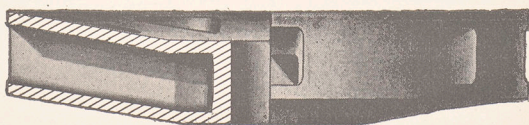

Price pr 100 kg. -----



THE BOFORS-GULLSPÅNG CO., LIMITED, BOFORS.

Center for Locomotiv Turntable.

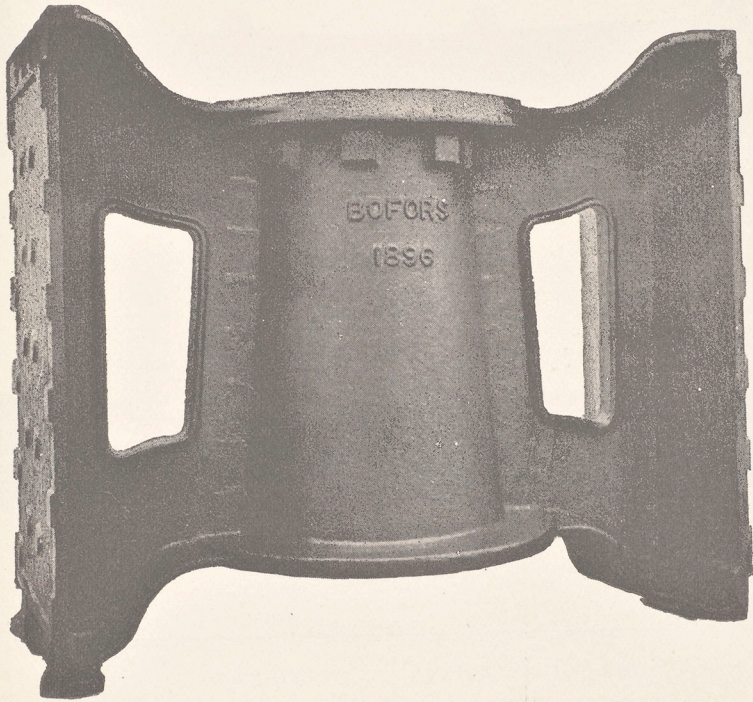

Price pr 100 kg. -----

Railway

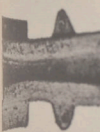

WEIGHT

Kilograms

150—

175—

200—

225—

250—

300—

above

Railway Crossings.

Double Point.

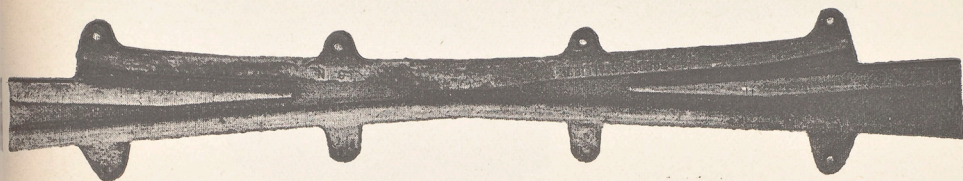

Single Point.

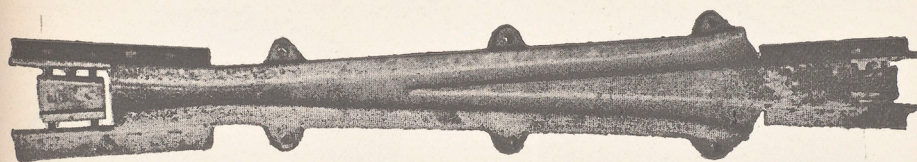

WEIGHT	PRICE PR 100 KG.
Kilogram	Kilogram
150—175	
175—200	
200—225	
225—250	
250—300	
300—350	
above 350	



Weight

Wabblers.

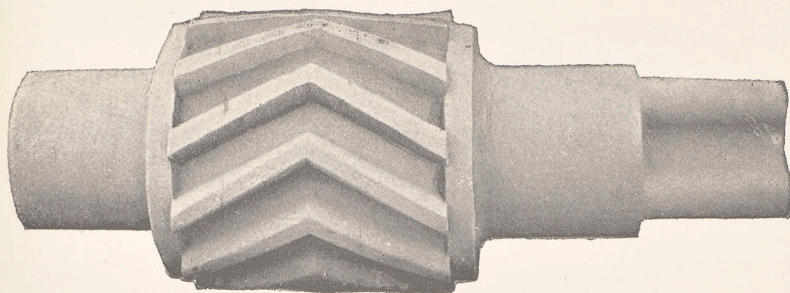

Weight

Pinions.

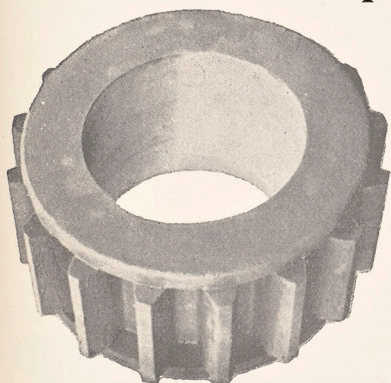

Weight

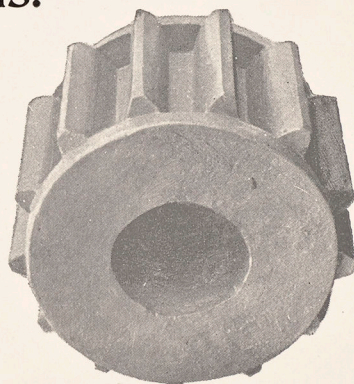

Weight

WEIGHT	PRICE PR 100 KG.
Kilogram	
50—75	
75—100	
100—200	
200—400	
above 400	

Cog Wheels and Cog Wheel Rings.

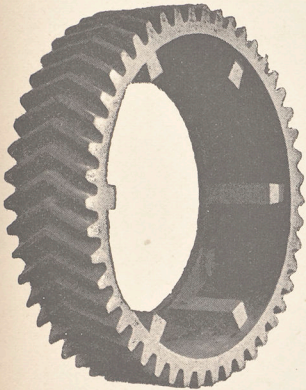

Weight

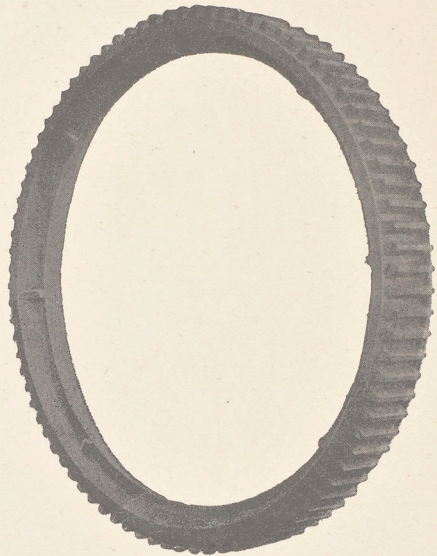

Weight

Cog Segment.

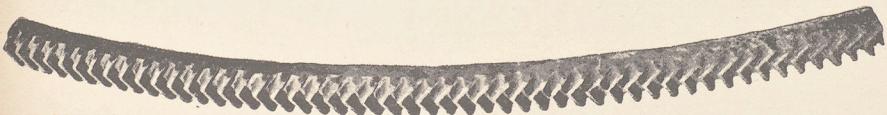

Weight

WEIGHT	PRICE PR 100 KG.	WEIGHT	PRICE PR 100 KG.
Kilogram		Kilogram	
Below 5		30-40	
5-8		40-60	
8-10		60-80	
10-12		80-150	
12-15		150-250	
15-20		250-600	
20-25		above 600	
25-30			

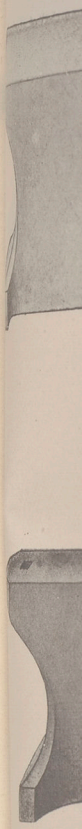

Anvils.

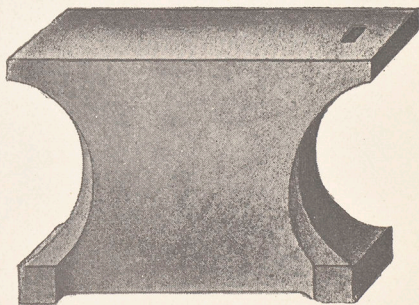
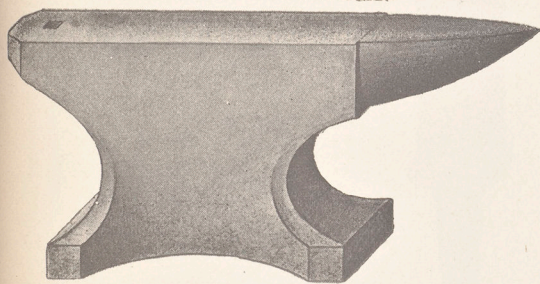
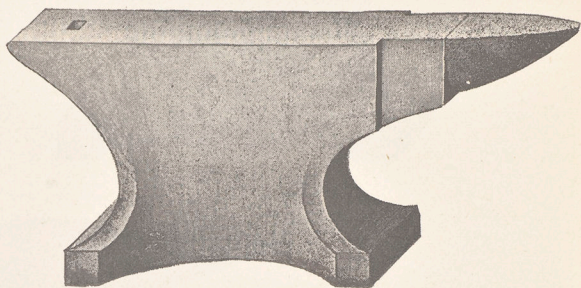
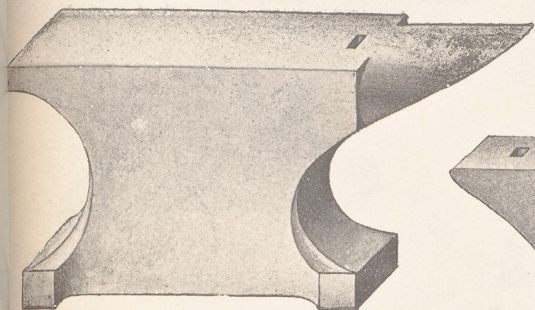

WEIGHT	PRICE PR 100 KG.
Kilogram	
Below 45	
45—80	
above 80	

Anvils.

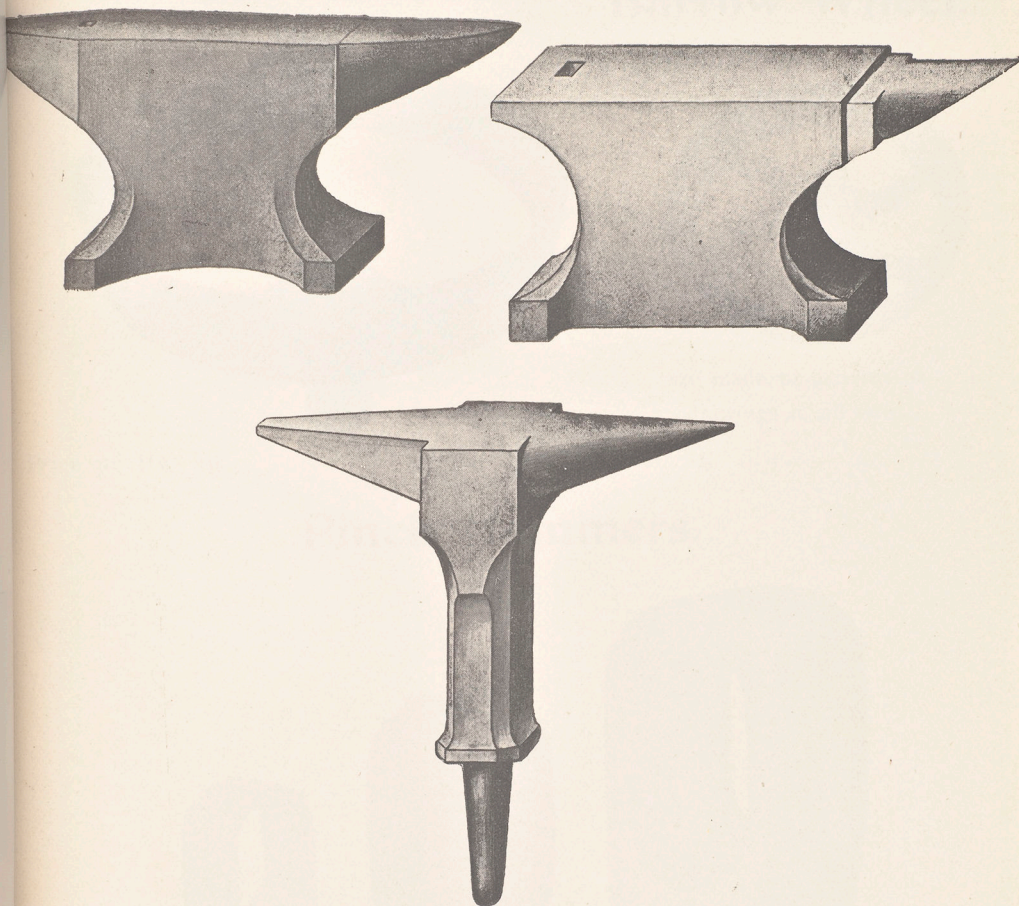

WEIGHT	PRICE PR 100 KG.
Kilogram	
Below 45	
45—80	
above 80	

Ladl



100 kg.



Ladle Belt.

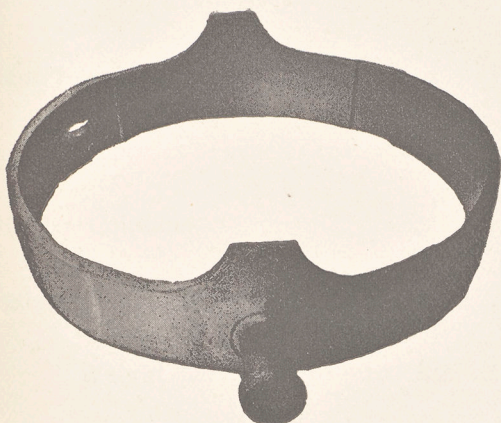

Barrow Wheel.

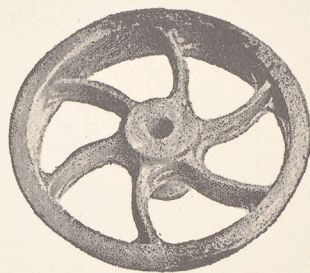

Are made to patterns or drawings in all sizes.

Price pr 100 kg.

Price pr 100 kg.

Pinch Hammers.

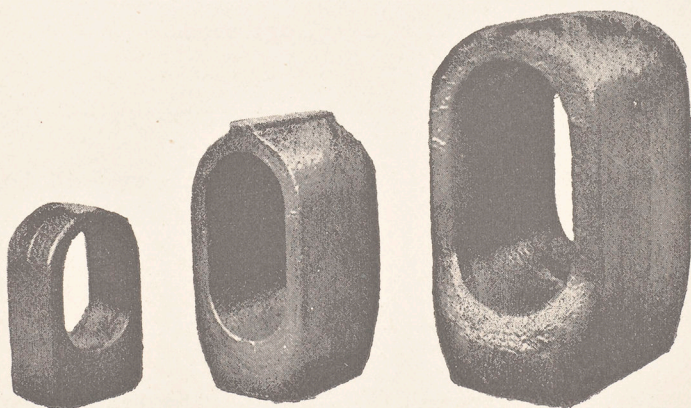

WEIGHT	PRICE PR 100 KG.
Kilogram	
20—30	
30—40	
40—60	
60—80	
80—100	
100—150	
150—200	

Lever.....

Stopper.....

Columns

Ladlelips

Weight per

.....

and Firebar

Covers

Collars

Rollies or She

THE BOFORS-GULLSPÅNG CO., LIMITED, BOFORS.

	Price pr 100 kg.
Chain Lever	
Chain Stopper	
Cylinder Columns	
Dredging Ladlelips	
Weight per piece 30—40 kg.	
» 40—50 »	
» 50—150 »	
» above 150 »	
Bearings	
Gratings and Firebars	
Manhole Covers	
Manhole Collars	
Block Pullies or Sheaves	

THE BOFORS

Shafts not turn

Diam. of Sha

Parts of comp

as a rule,

can be supplied

	Price pr 100 kg.
Crank Shafts not turned but crank milled out	
Diam. of Shaft 75 mm. and below	
» 76 mm. up to 120 mm.	
» 120 mm. and above	
.....	

Parts of compound Crankshafts (solid or hollow) are supplied, as a rule, at the same prices as straight axles. They can be supplied rough-turned or completely finished.

shafts solid cas

ered

Shaft 500 mm

400 »

300 »

200 »

100 »

ed and rough-

m of the shaft

Shaft 500 mm

400 »

300 »

200 »

THE BOFORS-GULLSPÅNG CO., LIMITED, BOFORS.

Price pr 100 kg.
Plain Shafts solid cast with or without Collars rough- turned
Diam. of Shaft 500 mm.
» 400 »
» 300 »
» 200 »
» 100 »
Hollowed and rough-turned. The hole is equal to half diam. of the shaft
Diam. of Shaft 500 mm.
» 400 »
» 300 »
» 200 »

THE BOFORS-GULLSPÅNG CO., LIMITED, BOFORS.

	Price pr 100 kg.
Clamps for Railway Crossings	
Buffer Hooks	
Axlebox Guides for Locomotives	
Buffers	
Buffer Boxes	
Buffer Guides	

Bois

Catches

Rolling Mills

THE BOFORS-GULLSPÅNG CO., LIMITED, BOFORS.

	Price pr 100 kg.
Cog Rods	
Coupling Rods	
Coupling Catches	
Breakers	
Shafts for Rolling Mills	
Roll Frames	

April Blocks

Weig

Pullies fo

THE BOFORS-GULLSPÅNG CO., LIMITED, BOFORS.

	Price pr 100 kg.
Anvil Blocks	
Weight per piece 300—400 kg.	
» 400—600 »	
» 600—800 »	
» above 800 »	
Pullies for Drop Hammers	
.....	
.....	
.....	
.....	
.....	

for hydraulic

Weight pr p

for Press Plate

Press Tabl

for horizontal

for Crushing

hydraulic Ram

for Lifting Cra

Columns

breaker Jaws ..

Bells for Churo

THE BOFORS-GULLSPÅNG CO., LIMITED, BOFORS.

		Price pr 100 kg.
Plungers for hydraulic Rams		
Weight pr piece	50—75 kg.....	
»	75—100 »	
»	100—150 »	
»	150—200 »	
»	200—300 »	
»	300—400 »	
»	above 400 »	
Hydraulic Press Plates		
»	»	
»	Press Tables	
Rollers for horizontal Woodpulp Machines		
Excenters for Crushing Machines		
Small hydraulic Rams		
Parts for Lifting Cranes		
Bridge Columns		
Stonebreaker Jaws		
Steel Bells for Churches etc.....		

Wheels

for Horse Nail

and Piping ...

for hydraulic

Weight pr pi

for Forgings

THE BOFORS-GULLSPÅNG CO., LIMITED, BOFORS.

		Price pr 100 kg.
Chain Wheels		
Parts for Horse Nail Machines		
Valves and Piping		
Lever for hydraulic rivetting Machines		
Weight pr piece	50—75 kg.	
»	75—100 »	
»	100—150 »	
»	150—200 »	
»	200—250 »	
»	250—300 »	
»	above 300 »	
Moulds for Forgings		

THE BOFORS

galvanizing p

Weight pr pie

ulations for

necessary

THE BOFORS-GULLSPÅNG CO., LIMITED, BOFORS.

		Price pr 100 kg.
Pans for galvanizing purposes		
Weight pr piece	10—15 kg.	
»	15—20 »	
»	20—25 »	
»	25—30 »	
»	30—40 »	
»	40—60 »	
»	60—80 »	
»	80—100 »	
»	100—150 »	
»	150—300 »	
»	300—600 »	
»	above 600 »	

Quotations for all kinds of Steel Castings given on receiving necessary particulars.

for galvanizing

Weight pr p

Quotations f
being necessary

THE BOFORS-GULLSPÅNG CO., LIMITED, BOFORS.

		Price pr 100 kg.
Pans for galvanizing purposes		
Weight pr piece 10—15 kg.		
» 15—20 »		
» 20—25 »		
» 25—30 »		
» 30—40 »		
» 40—60 »		
» 60—80 »		
» 80—100 »		
» 100—150 »		
» 150—300 »		
» 300—600 »		
» above 600 »		

Quotations for all kinds of Steel Castings given on receiving necessary particulars.

